

# WINCO<sup>®</sup> GENERATORS

 An American Company

We produce our products in our 200,000ft<sup>2</sup> facility located in Le Center, Minnesota, equipped with modern engineering, fabrication and assembly capabilities.



Full Load Tested

Every generator is 100% load tested



DSE 7310 Controller

Provides immediate performance information



Coolant Heater

120V in-line Hotstart coolant heater with thermostat



Battery Charger

5 Amp, smart marine charger standard



TÜV Certified

The design, construction, and performance of our stationary generators conform to UL2200 & CSA standards



# PSS60F4 60,000 WATTS

Rugged Design.

Durable enclosure with powder coat paint



Industrial Ford Engine.

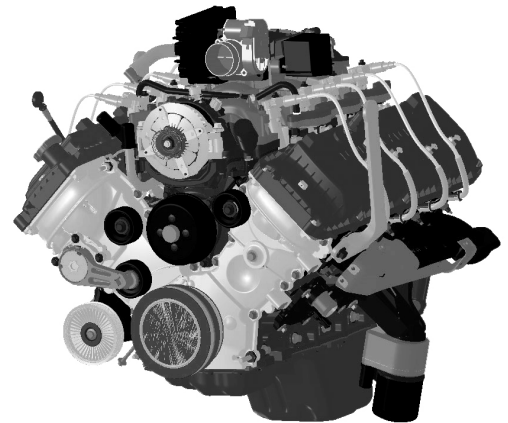

Cummins Industrial Genend.



# SPECIFICATIONS

## ELECTRICAL

VOLTS	P.F.	STANDBY						PRIME						MAIN CB
		LP			NG			LP			NG			
		WATTS	KVA	AMPS	WATTS	KVA	AMPS	WATTS	KVA	AMPS	WATTS	KVA	AMPS	
120/240 1-PH	1.0	60,000	60.0	250	60,000	60.0	250	54,000	54.0	225	54,000	54.0	225	250
120/208 3-PH	0.8	62,000	77.5	215	62,000	77.5	215	56,420	70.5	196	56,420	70.5	196	225
120/240 3-PH	0.8	62,000	77.5	186	62,000	77.5	186	56,420	70.5	169	56,420	70.5	169	225
277/480 3-PH	0.8	62,000	77.5	93	62,000	77.5	93	56,420	70.5	84	56,420	70.5	84	100
346/600 3-PH	0.8	62,000	77.5	75	62,000	77.5	75	56,420	70.5	67	56,420	70.5	67	80

## ENGINE

ENGINE BRAND	FORD
ENGINE MODEL	RSG 862
ENGINE STARTER	12V ELECTRIC
ENGINE SPEED	1800 RPM
ENGINE CYLINDERS	8
ENGINE HP	
NG	108
LP	119
FREQUENCY <sup>(1)</sup>	60 HZ
ALTERNATOR	157 AMP
FLYWHEEL	11.5"
ROTATION	CW
ASPIRATION	NATURAL
BORE/STROKE	102 mm x 95 mm
DISPLACEMENT	6.2L
LOW OIL PROTECTION	STANDARD
RECOMMENDED OIL <sup>(2)</sup>	5W-30
OIL CAPACITY	7 QT
GOVERNOR	ELECTRONIC
COMPRESSION RATIO	9.8:1
FAN TYPE	PUSHER
COOLANT	6.3 GAL
RADIATOR COOLING AIR	5,560 CFM
EXHAUST FLOW	510 CFM
EXHAUST OUTLET SIZE	4"
COMBUSTION AIR	168 CFM
STARTING TEMP W/BLOCK HEATER	--

NOTES: (1) Steady state frequency regulation. (2) The recommended oil is for normal applications. See operator's manual for the recommended oil for your needs.

## PSS60

MOTOR STARTING (CODE G)	20 HP
DBA @ 7 METERS	72
TOTAL HARMONIC DISTORTION	< 5%
FLOATING NEUTRAL	YES
ASSEMBLED IN	USA
EPA APPROVED	YES
CARB APPROVED	YES
TÜV CERTIFICATION	UL2200 CSA
UNIT WARRANTY <sup>(1)</sup>	
STANDBY	2 YEAR/2000 HRS

NOTES: (1) For more generator warranty, see operator's manual.

## GENERATOR END

WINDING	
SINGLE PHASE	4 LEAD
THREE PHASE	12 LEAD
WINDING NUMBER	
SINGLE PHASE (PRIME)	06
SINGLE & THREE PHASE	311
VOLTAGE REGULATION	AVR +/- 1%
AVR TYPE	SX440
TEMPERATURE RISE	125/40° C
TYPE	REVOLVING FIELD
BRUSHLESS	YES
SPEED	1800 RPM
ROTOR	2/3 PITCH
WINDINGS	100% COPPER
STATOR WINDING	DOUBLE LAYER CONCENTRIC
COUPLING	DIRECT/FLEXIBLE DISC
BEARINGS	SINGLE (MAINTENANCE FREE)
EFFICIENCY PEAK	
SINGLE PHASE	84.2
THREE PHASE	90.4
INSULATION	CLASS H
INGRESS PROTECTION	IP23

# SPECIFICATIONS

## DERATES

ABOVE SEA LEVEL > 2000 ft	2% EVERY 500 FEET
AMBIENT TEMPERATURE > 104°F	4% EVERY 10°F

NOTES: (1) Generator rating is based on 1,000 ft above sea level

## BLOCK HEATER

VOLTS	120
WATTS	1,800
AMPS	15
THERMOSTAT ON	100° F
OFF	120° F

## FUEL

INLET PRESSURE	4-6 OZ/7-11" WATER COLUMN
FUEL INLET SIZE	1.25"
FUEL CONSUMPTION NG	
100%	760 FT <sup>3</sup> /HR - 797,416 BTU/HR
75%	617 FT <sup>3</sup> /HR - 647,900 BTU/HR
50%	475 FT <sup>3</sup> /HR - 498,385 BTU/HR
25%	332 FT <sup>3</sup> /HR - 348,870 BTU/HR
FUEL CONSUMPTION LP	
100%	8.2 GAL/HR - 750,685 BTU/HR
75%	6.7 GAL/HR - 564,220 BTU/HR
50%	5.1 GAL/HR - 466,889 BTU/HR
25%	3.6 GAL/HR - 329,569 BTU/HR

## DSE 7310 CONTROLLER

### ENGINE DISPLAY/PROTECTION

ENGINE RPM	YES
LOW OIL PRESSURE	YES
HIGH COOLANT TEMP	YES
LOW COOLANT	YES
OVER/UNDER SPEED	YES
OVER CRANK	YES
CAN ECU SHUTDOWN	YES
ENGINE MAINTENANCE CODES	YES

### GENSET DISPLAY/PROTECTION

VOLTAGE (L-N & L-L)	YES
OVER/UNDER VOLTAGE	YES
FREQUENCY	YES
OVER/UNDER FREQUENCY	YES
AMP DISPLAY/SHUTDOWN	YES
PHASE IMBALANCE	FIELD ENABLED
KW, KVA, KVARH DISPLAY	YES
KWH, KVAH, KVARH DISPLAY	YES
GENERATOR PHASE SEQUENCE	OPTIONAL

## BATTERY

DC SYSTEM	12V
BATTERY RACK/CABLE	INCLUDED
BATTERY CHARGER	5 AMP
REQUIRED BATTERY <sup>(1)</sup>	GROUP 24 650 CCA

NOTES: (1) Battery is not included.

## SHIPPING

SHIP DIMENSIONS (L x W x H)	115.5" x 48" x 65"
SHIP WEIGHT	2390 LBS
FREIGHT CLASS	70

NOTES: Shipping dimensions are for an enclosed unit.

## OPTIONAL ACCESSORIES

GENERATOR STRIP HEATER
AUTOMATIC TRANSFER SWITCH
PERMANENT MAGNET GENERATOR
VAPOR FUEL STRAINER
BATTERY CHARGER UPGRADE
BATTERY HEATER
NFPA 110 LEVEL 1
WEBNET
LP LIQUID WITHDRAWAL

### ADDITIONAL DISPLAYS/PROTECTIONS

EXTERNAL E-STOP	FIELD INSTALLED
BATTERY VOLTAGE	YES
BATTERY OVER/UNDER VOLTAGE	YES

### COMMUNICATIONS

USB CONNECTABLE	YES
RS232/RS485	YES
REMOTE DISPLAY PANEL	OPTIONAL
DSE WEB NET	OPTIONAL

### ADDITIONAL FEATURES

AUDIBLE ALARM	YES
ENGINE EXERCISER	FIELD ENABLED
MAINTENANCE INTERVAL TIMER	FIELD ENABLED
LOAD SHEDDING/DUMMY	FIELD ENABLED
CONFIGURABLE INPUTS	4 (EXPANDABLE)
CONFIGURABLE OUTPUTS	4 (EXPANDABLE)
EVENT LOG	250

# DRAWINGS

## OPEN

KEY COMPONENTS	
A	ENGINE CONTROL
B	MAIN LINE CIRCUIT BREAKER
C	OIL FILL
D	OIL DRAIN
E	OIL DIPSTICK
F	OIL FILTER
H	FUEL INLET
I	AIR FILTER
J	COOLANT DRAIN
K	COOLANT FILL
L	AVR
M	BATTERY CHARGER
N	BLOCK HEATER
O	BATTERY

### TOP VIEW HOLE PATTERN

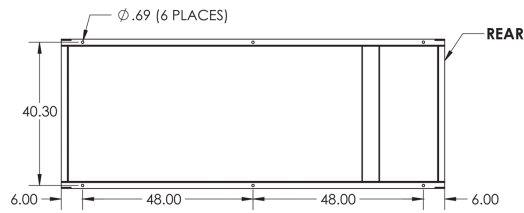

### TOP

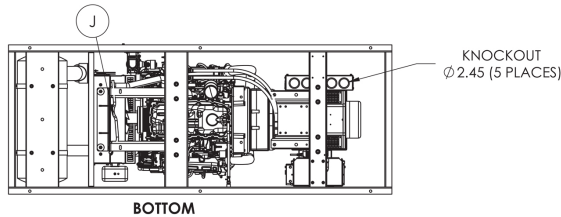
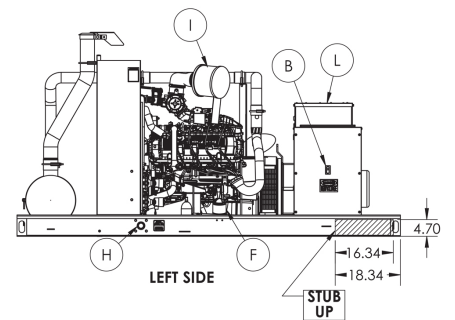
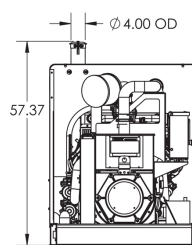
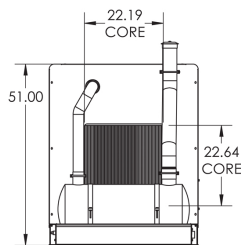
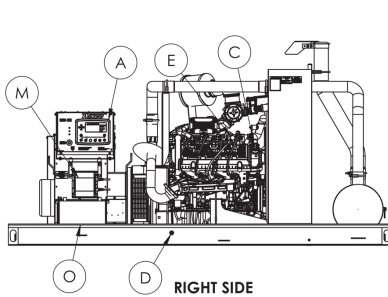
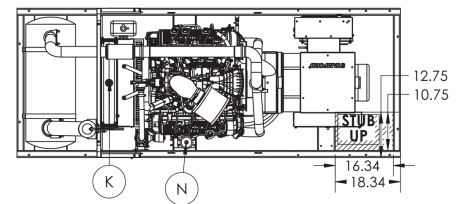

## ENCLOSED

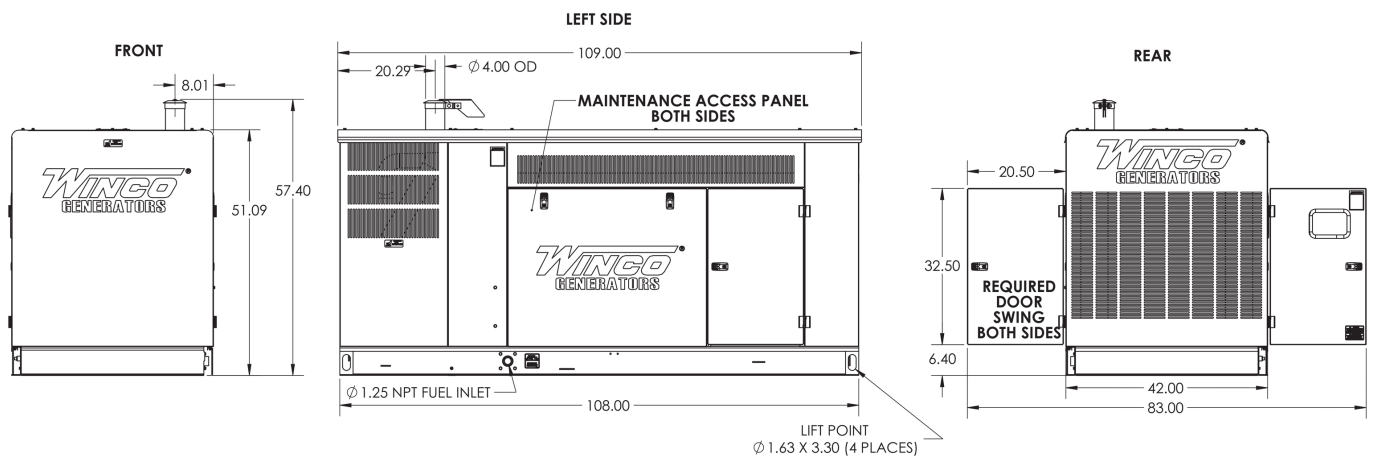

Specifications are subject to change without notice.

